



Network Surveillance Server

NSR-1200

NSR-1100

NSR-1050H

IPELA

Stunning video and audio brought to you by the "IPELA" series of visual communication products that encompass the three-pronged concept of "Reality," "Intelligence," and "Usability." "IPELA" is the identity symbolizing the Sony vision for the workplace of the future, connecting people, places, and information with reality that has never before been achieved. "IPELA" lets you share, understand, and experience as if you are actually there, when in fact, you are miles away. It allows you to quickly grasp a situation to make better business decisions.

Real audiovisual communication over networks – this is business communication of the future, this is business communication brought to you today, this is "IPELA."

NSR-1000 Series

Reality

- High Frame Rate
- Dynamic Frame Integration

Intelligence

- Video Motion Filter Alarm
- Video Motion Filter Search
- Intelligent Setup

Usability

- Intuitive Remote Control Unit
- User-Friendly GUI
- Quick Search/Playback

Hybrid, Open-platform, Easy-to-operate Network Surveillance Server

The demand for surveillance systems is growing, and the adoption of IP as a transport mechanism for video is ever increasing. Sony recognized this trend early on, and has been focused on developing products and solutions aligned with this trend. Now, Sony is pleased to announce the introduction of the NSR-1000 Series of recording servers.

The key concept of the NSR-1000 Series is a hybrid capability – with an open-platform design, these recording servers support both legacy analog and current IP cameras, and are easy to setup and operate. With the NSR-1000 Series, you'll open doors to a world of new possibilities in video surveillance.

	NSR-1200	NSR-1100	NSR-1050H
Internal storage	2 TB	1 TB	0.5 TB
Max. number of IP/Analog cameras supported*1	64 Units	32 Units	20 Units
Max. number of analog cameras supported (directly connected)	Option (16 Inputs)	Option (16 Inputs)	Standard (16 Inputs)
Max. number of megapixel cameras supported at full resolution	8 Unit	4 Unit	4 Unit
Max. frame rate for recording*2	480 fps	240 fps	120 fps
HDMI outputs	2	2	2
RAID	RAID 5	RAID 0	-

*1 Total of IP and analog cameras. *2 Without local displays.

Why Choose the NSR-1000 Series?

Hybrid System

Easy to Migrate From Analog to IP Camera Systems

Up to 16 analog cameras can be connected to the NSR-1000 Series (NSR-1050H: directly connected; NSR-1200/1100: connected using the NSBK-A16 Analog Encoder Kit). You can simply add network cameras, including megapixel cameras, while maintaining your analog cameras.

Easy to Migrate to Large-screen HDTV Display Systems

The NSR-1200/1100/1050H has two analog RGB and two HDMI monitor output connectors on the rear panel. You can use two of these four outputs simultaneously in any combination to meet your system requirements.

Easy to Migrate to HD Camera Systems

In answer to growing demands for HD (High Definition) network cameras, the NSR-1200/1100/1050H will offer this migration capability in the near future.

Open Platform

Free to Select From a Wide Range of Cameras

The NSR-1200/1100/1050H can be used not only with Sony's network cameras but also with other major brand network cameras.

Quick Setup & Easy Operation

Quick Setup

With the set-up wizard, you can set up the system in a simple and straightforward manner.

With Sony's IP cameras, the NSR-1200/1100/1050H detects cameras instantly, drastically reducing the time required for system installation. Images from cameras are assigned automatically to Monitor Layout, so that you can start monitoring instantly.

Features

High Quality Display Capability

High Frame Rate Display

The video readout frame rate of the NSR-1200/1100/1050H is much higher than that of conventional models. With the NSR-1200 connected with 16 cameras, video movement (VGA, MPEG-4) can be viewed through a monitor much more clearly and smoothly at approximately 25 fps.

HDMI Outputs for Full HD Displays

You can view and monitor video via the HDMI interface with Full HD (1920 x 1080) displays. If you use megapixel cameras, you can view full-resolution images with this equipment. What's more, you can set a six-screen display layout and still view VGA video in full resolution.

Application of Full HD Display

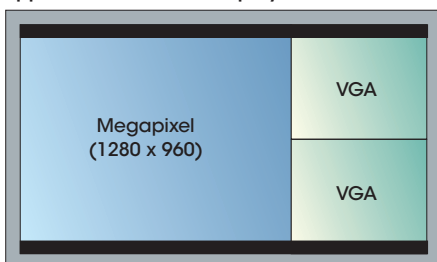

Megapixel x1, VGA x2

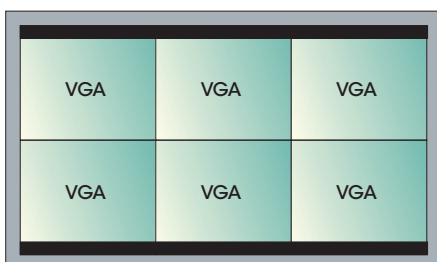

VGA x6

Expandability and Flexibility

Additional Storage of Up To 2 TB x 7

The NSR-1200/1100/1050H has an internal storage of up to 2 TB/1 TB/0.5 TB respectively. Each server can be connected up to seven NSRE-S200 units, a 2 TB hard disk storage device. With the NSR-1200 in RAID 5 configuration and seven NSRE-S200 units, the total recording capacity is approximately 11 TB (max.).

Remote Viewing by Controller Software

If you install the bundled Controller Software on a personal computer in a remote location, you can supervise NSR-1200/1100/1050H recording servers simultaneously in various locations, with flexibility in selecting and viewing live and recorded images.

IMZ-NS100 Series

In the same series of software solutions, Sony also provides the IMZ-NS101/NS104/NS109/NS116/NS132 Intelligent Monitoring Software. This can be installed on your own Microsoft Windows server to monitor and control 1/4/9/16/32 network cameras, respectively. It features the same functionality and graphical user interface as the NSR-1200/1100/1050H. The supplied Controller Software can be used for multiple NSR-1200/1100/1050H servers with IMZ-NS100 Series software.

Monitoring & Quick Search (Intuitive Main GUI)

The Main GUI (Graphical User Interface)

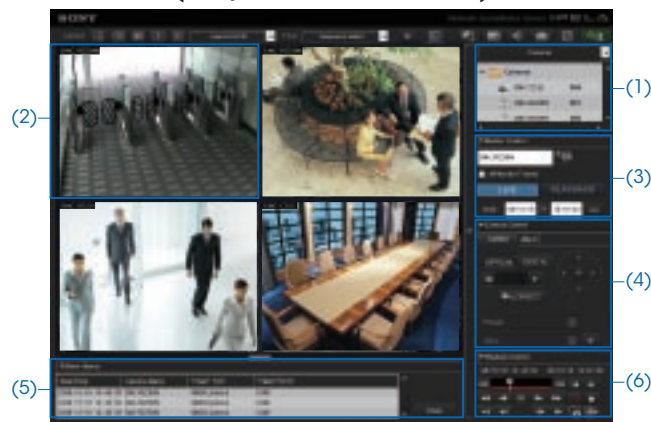

With the user-friendly GUI, you can use various monitoring functions with intuitive operation, such as drag-and-drop. You can also run a quick search, and playback recorded images, while monitoring.

- (1) Camera Pane (2) Monitor Frame (3) Monitor Control
- (4) Camera Control (5) Alarm List (6) Playback Control

Drag-and-drop Operation (Camera Switching)

All connected cameras are shown in a tree configuration in the Camera Pane (1). By dragging a camera icon and dropping it onto a Monitor Frame (2), you can easily view live images from a camera.

Easy-to-use Monitoring Functions

Each Monitor Frame (2) shows the status of the video (live or recorded), and the name of the camera, above each video image. Up to 8 x 8 Monitor Frames can be used.

By double-clicking a specific Monitor Frame, the display is switched to Single Monitor Frame mode as below.

By Double-clicking a Frame

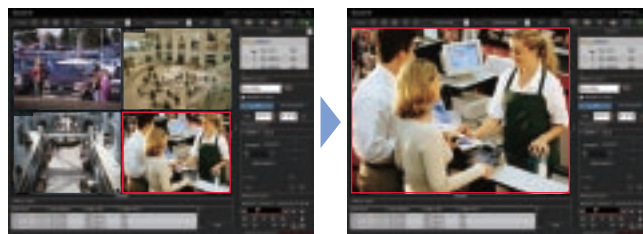

Hot Spot Monitoring/Dual Monitor Support

A specific window in a multi-camera view (i.e. a larger window within the multi-camera window) can be assigned as the Hot Spot area, or a second monitor may be used for this purpose.

The Hot Spot area is used to display an image of interest to get a more detailed view – this image can be manually selected or triggered by an alarm.

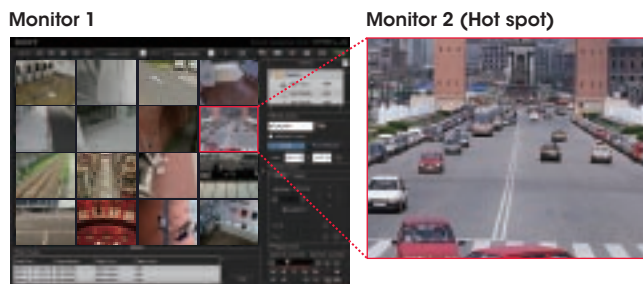

Features

Camera Pan/Tilt/Zoom (PTZ) Control

PTZ network cameras from Sony and other supported brands can be controlled by the Camera Control pane (4). In PTZ Direct Control mode, when a point in the image is clicked, the camera automatically pans and tilts to make that point the center of the image. You can also zoom into the image simply by dragging out the specified area of the image with a mouse.

Zoom

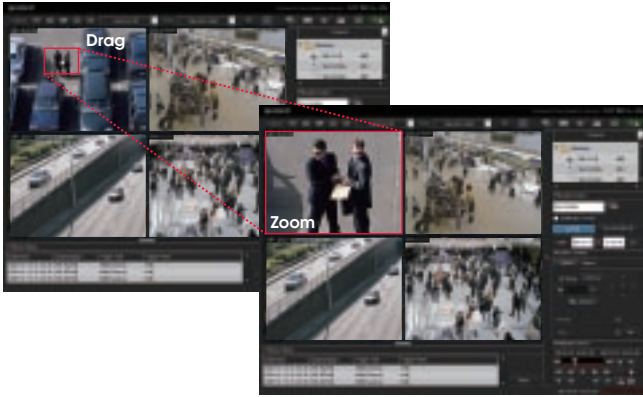

Audio Monitoring

The sound from a microphone connected to the camera can be monitored at the NSR-1200/1100/1050H server. The audio signal is output from the HDMI or the audio connectors on the rear panel of the NSR-1200/1100/1050H.

Quick Search and Playback While Monitoring

If you click PLAYBACK in the Monitor Control pane (3), you can play back the images recorded a certain number of seconds before (this is initially set in the GUI Setting menu). You can also quickly search for the recorded image by date/time search in the Monitor Control pane.

Alarm List Playback

When an alarm recording is executed, the date, time, and the camera name are noted in the Alarm List (5). Simply by double-clicking a line in the alarm list, you can play back the recorded image.

Playback Control and Data Export

With the Playback Control pane (6), you can control the playback functions such as slow and reverse/forward. You can also export the still or moving images of your specified date and time to external media, such as CD-R, DVD-R, and USB Flash Memory.

Customized Layouts

The Layout Editor is a powerful feature that creates customized site layouts and allows the user to insert backgrounds (e.g., a floor plan or campus layout), camera icons, and company logos.

Monitoring GUI (Customized)

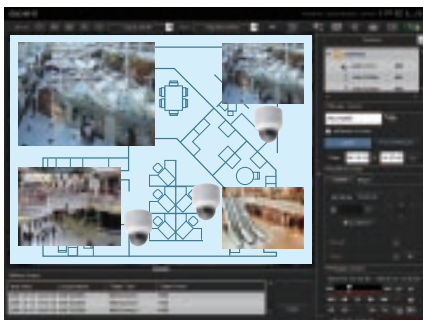

Sophisticated Search Functions

Dedicated Search Menu



- (1) Switching Tab (Normal Search/Object Search)
- (2) Search Menu (Search Conditions, VMD, DEPA Setting, etc.)
- (3) Image Control (Zoom, etc.)
- (4) Playback Control (Reverse, Forward, Stop, etc.)
- (5) Display Area (Playback of Searched Images)
- (6) Search Result Area

Two Search Functions

With the Switching Tab (1), you can select either Normal Search or Object Search.

• Normal Search

You can search for specific images by setting search conditions such as the camera name, date, time, and the type of recording (manual/schedule/alarm/event).

• Object Search

You can search for specific images in the recorded video using intelligent functions. There are two types of search – Post VMD (Video Motion Detection), and VMF (Video Motion Filter). With Post VMD, you can search for images in the recorded video with search conditions that are set after the recording, such as specific object movements. (see below 1) With VMF, you can search for images in the recorded video using DEPA (Distributed Enhanced Processing Architecture) system features. With a VMF search, you should record metadata with DEPA-enabled cameras during the video recording. For example, you can count the number of people who passed a line that is set on the screen. (see below 2) (Please refer to “What is DEPA?”)

1. Post VMD Search



2. VMF Search

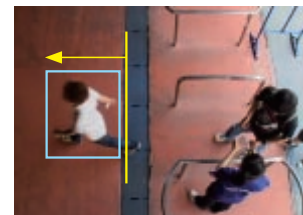

What is DEPA?

In conventional video analytic systems, the camera only sends video images to recorders, and video image analysis is processed solely on the recorder side. In Sony's DEPA system, the DEPA-enabled camera sends to the DEPA-enabled recorder not only video images but also related metadata such as the camera ID, date/time, and information about the shot object (size and position). The recorder checks this metadata with a search filter called a VMF (Video Motion Filter), to send an alarm signal when the metadata matches a preset condition of the VMF. Since the partial image processing is done on the camera side, the system can be configured in a much simpler manner, and can be expanded more easily.

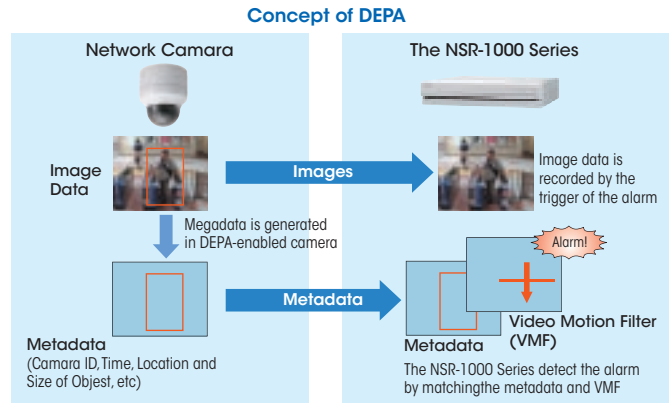

Search Results by Timeline or List

The search result is displayed either by timeline or list. In a timeline chart, search results are displayed in different colors depending on the type of recording. You can easily playback video just by clicking on a specific part of the timeline, or on the list.

Timeline Mode

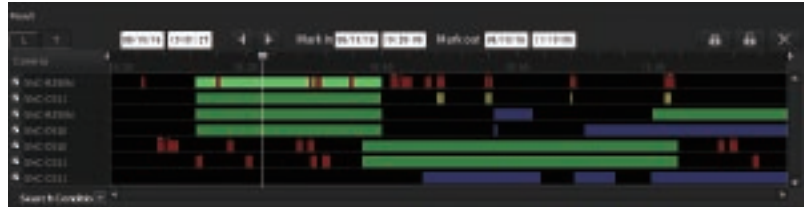

List Mode



Versatile Recording Functions

There are various recording functions:

Manual Recording

Manual Recording is started manually anytime the operator wants.

Schedule Recording

Schedule Recording is started based on a set schedule.

Alarm/Event Recording

There are two types of alarm-triggered recording - Alarm and Event (i.e., Activity) Recording. While it is important to initiate recordings based on video motion detection or alarm signal input, it is also helpful if the user can define what is considered an alarm. For example, a camera may be looking at an area where there are people moving about during office hours, but the recording of such motion should not be considered a true alarm; it is rather a normal event or activity. However, such motion out of office hours should be considered a true alarm, and an action or alert needs to be initiated. The former is performed by Event Recording and the latter by Alarm Recording. The date/time of Alarm Recording is listed in an Alarm List in the main GUI (but this does not occur with Event Recording). Having this capability accomplishes two things - it saves on storage (with motion/alarm recording only), and reduces seek times when searching Alarms and Events.

Schedule Recording with Alarm Marking

While using Schedule Recording, the time when the alarm is detected can be marked in the timeline. This function enables images to be searched quickly.

Alarm/Event Recording

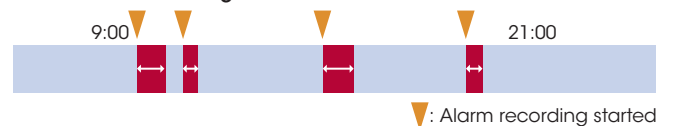

Schedule Recording



Schedule Recording with Alarm Marking



Features

Other Key Features

MPEG4/JPEG Dual Stream

Connected with the SNC-RX Series, SNC-DS10, SNC-DM110, and later models from Sony, the NSR-1200/1100/1050H can accept both JPEG and MPEG4 from cameras at the same time. With a limited storage capacity, for example, you can monitor live video via MPEG4 at frame rates as high as 30 fps, and record video via JPEG at frame rates as low as 1 fps.

Light Funnel Control for Higher Sensitivity

Light Funnel is a technology in Sony's megapixel network cameras to provide higher sensitivity. By combining the information of four pixels and handling them as a single pixel, this type of camera provides sensitivity four times higher than conventional cameras. With the NSR-1200/1100/1050H, there is a menu to control the Light Funnel settings of applicable cameras; this simplifies control. (Please note that when Light Funnel technology is applied to a 1280 x 960 image, its size becomes 640 x 480.)

Image of Light Funnel Function

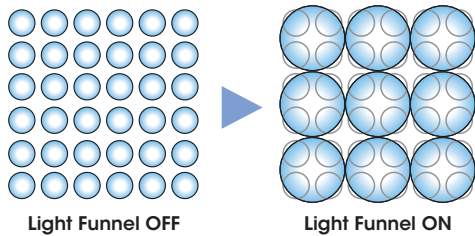

Flexible User Management Setting

All access to the NSR-1200/1100/1050H is managed by user authorization, which is set by the system administrator. The administrator can simply provide each user with a permission level selected from the five ready-made levels of operational permission, or set the accessibility in a more customized way. The accessible cameras for each user can be set for each camera, or for each NSR-1200/1100/1050H server. When the system is configured with more than one NSR-1200/1100/1050H server, all user information is shared throughout the whole system.

Others

- Privacy Zone Masking
- Data Export to CD-R, DVD-R, USB Media, etc

System Examples

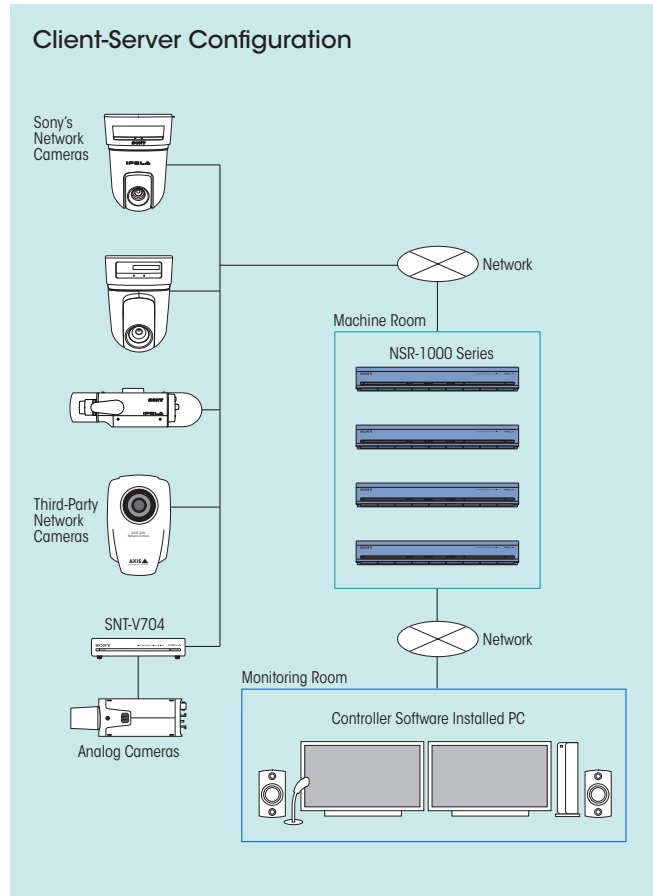
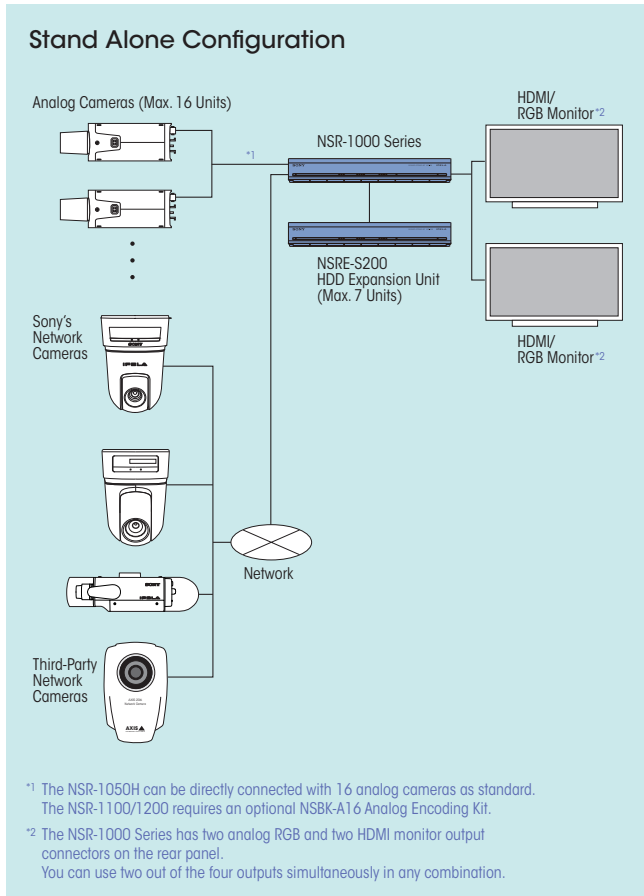

Optional Products



NSBK-A16
Analog Encoding Kit



NSRE-S200
HDD Expansion Unit



SNT-V704
Video Network Station



NSR-RM1
Rack Mount Kit

Connectors

Front Panel (Cover Open) NSR-1200/1100/1050H

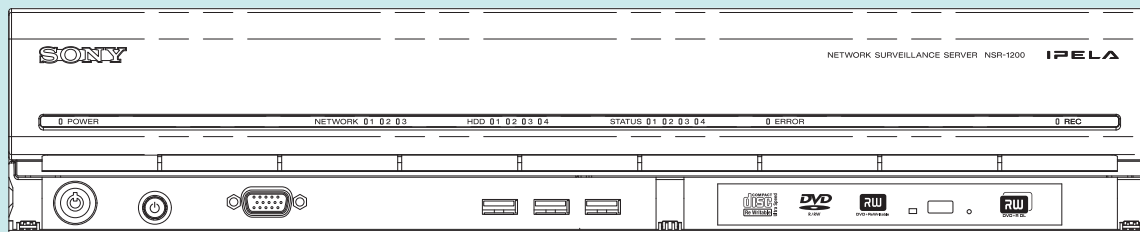

Rear Panel NSR-1200/1100

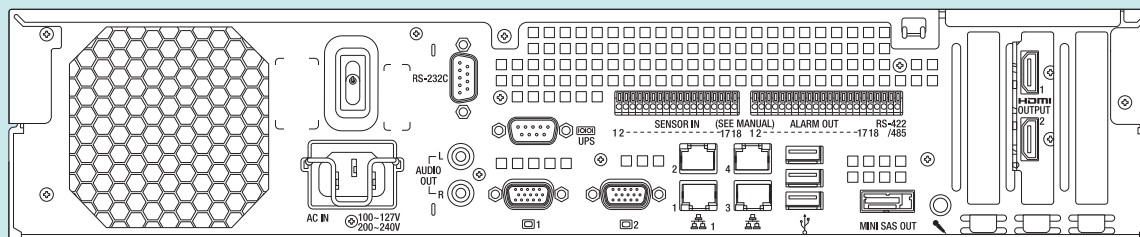

Rear Panel NSR-1050H

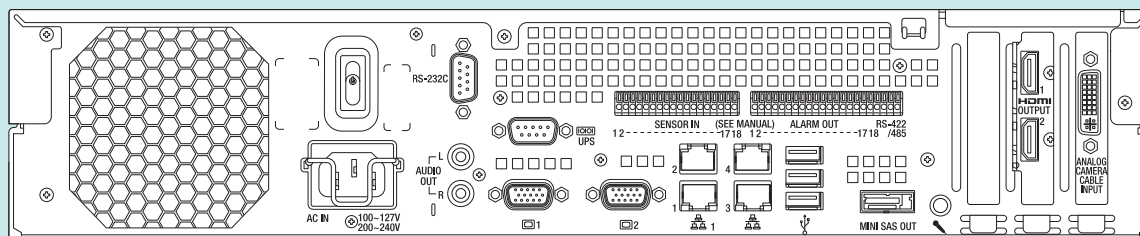

Rear Panel NSRE-S200

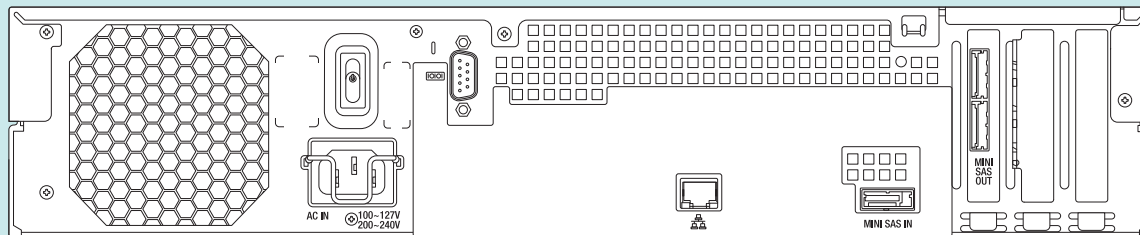

Specifications

	NSR-1200	NSR-1100	NSR-1050H
Video/Recording			
Number of cameras supported	Max. 64 (IP/Analog total)	Max. 32 (IP/Analog total)	Max. 20 (IP/Analog total)
Number of megapixel cameras to be connected	Max. 64	Max. 32	Max. 20
Number of megapixel cameras supported at full resolution	Max. 8	Max. 4	
Number of analog cameras	Option (NSBK-A16)		Max. 16
Video compression (IP camera)	MPEG-4 or JPEG		
Video compression (Analog camera)	Option (NSBK-A16)		MPEG-4
Maximum recording rate (IP/Analog total)*1	480 fps VGA (640 x 480) at JPEG, 480 fps CIF (352 x 240)	240 fps VGA (640 x 480) at JPEG, 480 fps CIF (352 x 240)	120 fps VGA (640 x 480) at JPEG, 480 fps CIF (352 x 240)
Hard disk drives (Physical capacity)	2 TB (500 GB x4)	1 TB (500 GB x2)	500 GB (500 GB x1)
Hard disk drives (Interface)	Serial ATA		
Hard disk drives (RAID level)	RAID 5	RAID 0	–
Hard disk drives (Recording capacity)	Approx. 1.366 GB	Approx. 886 GB	Approx. 443 GB
Optical disc drive	DVD/CD Drive x1 (DVD-R, DVD+R, DVD-ROM, CD-ROM, CD-R, CD-RW)		
Expansion storage	Supports NSRE-S200 (2000 GB) (Max. 7 Units)		
Analog Camera Input			
Analog camera interface			Video input x16, Audio input x4 (Supplied cable)
Video compression			MPEG-4
Resolution	Option (NSBK-A16)		NTSC: 704 x 480, 704 x 240, 352 x 240 PAL : 704 x 576, 704 x 288, 352 x 288
Maximum frame rate*2			NTSC: 120 fps 704 x 480, 240 fps 704 x 240, 480 fps 352 x 240 PAL : 100 fps 704 x 576, 200 fps 704 x 288, 400 fps 352 x 288
Video Output			
Monitor OUT 1 *3	HDMI (Type A) x1 and D-sub 15-pin x2 (Front and rear)		
Monitor OUT 2 *3	HDMI (Type A) x1 or D-sub 15-pin x1 (Rear)		
Audio Output			
Audio line OUT	RCA-pin L/R x1 Stereo Pair		
Sensor Input/Alarm Output			
Sensor input	8-channel photo-coupler (DC 3.3 to 24 V)		
Alarm output	8-channel mechanical relay (Max. DC 24 V/1 A)		
Other Interfaces			
Ethernet *4	1000BASE-T/100BASE-TX/10BASE-T x4 (Auto switching)		
USB	USB2.0 x3 (Front), USB2.0 x3 (Rear)		
Serial interface (for UPS)	RS-232C : D-sub 9-pin x1		
Serial interface (for analog camera control)*5	RS-232C : D-sub 9-pin x1, RS-422/485 x1		
Serial attached SCSI (SAS1.1)	SFF-8088 (mini-SAS 26-pin) x1		
General			
Dimensions (W x H x D)	430 x 87 x 417 mm (17 x 3 1/2 x 16 1/2 inches) excluding protrusions		
Mass	Approx. 13.5 kg (29 lb 12 oz)	Approx. 12 kg (26 lb 7 oz)	Approx. 11.5 kg (25 lb 6 oz)
Power requirements	AC 100 V to 127 V/ 200 V to 240 V (50/60 Hz)		
Power consumption	Approx. 265 W (typical) (Max. 350 W)	Approx. 185 W (typical) (Max. 350 W)	Approx. 175 W (typical) (Max. 350 W)
Operating temperature	5 to 40 °C (41 to 104 °F)		
Operation humidity	20 to 80 %		
Supplied accessories	Analog camera input cable (NSR-1050H only), Front panel key (2), Installation manual, First step guide, Monitoring window operations guide, Safety regulations, WEEE booklet, Warranty booklet, Rubber foot (4)		

*1 With 16 cameras connected. JPEG compression by a standard rate. *2 Total of all the channels. Maximum frame rate for one channel is 30 fps (NTSC)/ 25 fps (PAL). *3 More than one connector cannot be used at a time.

*4 Port #1 is for network connection. Port #2 is for connecting controllers. Port #3 and #4 is for the future expansion. *5 VISCA and Pelco-D are supported.

NSRE-S200		
Storage Capacity		
Physical capacity	2 TB (500 GB x4)	
Hard disk drive	Interface	Serial attached SCSI
	RAID level	RAID 5
	Recording capacity	Approx. 1.396 GB
Interfaces		
Ethernet	100BASE-TX/10BASE-T x1 (Auto switching) (For maintenance)	
Serial interface	RS-232C x1 (For maintenance)	
Serial attached SCSI (SAS1.1)	SFF-8088 (mini-SAS 26pin): input x1, output x2	
General		
Dimensions (W x H x D)	430 x 87 x 417 mm (16.9 x 3.4 x 16.4 inches) (Excluding protrusions)	
Mass	Approx. 12 kg (26 lb 7 oz)	
Power requirements	AC 100 to 127 V/200 to 240 V (50/60 Hz)	
Power consumption	Approx. 80 W (typical) (Max. 350 W)	
Operating temperature	5 to 40 °C (41 to 104 °F)	
Operating humidity	20 to 80 %	
Supplied accessories	Mini-SAS cable (1 m), Front panel key (2), Installation manual, Safety regulations, WEEE booklet, Warranty booklet, Rubber foot (4)	

NSBK-A16		
Video / Audio Interfaces		
Analog input	Number of analog input	Video input x16/Audio input x4
	Video compression	MPEG-4
	Input video format	NTSC or PAL
	Resolution	NTSC: 704 x 480, 704 x 240, 352 x 240 PAL : 704 x 576, 704 x 288, 352 x 288
	Maximum frame rate *6	NTSC: 120 fps 704 x 480, 240 fps 704 x 240, 480 fps 352 x 240 PAL : 100 fps 704 x 576, 200 fps 704 x 288, 400 fps 352 x 288
General		
Dimensions (Board)	Approx. 168 x 64 mm (6.6 x 2.5 inches)(exclusive projections)	
Cable length	Approx. 300 mm (11.8 inches)	
Mass	Board	Approx. 72 g (2.5 oz)
	Cable	Approx. 235 g (8.3 oz)
Connector	Input connector (Board)	DVI-connector
	Video input connector (Cable)	Composite BNC x16 (Black)
	Audio input connector (Cable)	RCA x4 (White)
Operating temperature	5 to 40 °C (41 to 104 °F)	
Operating humidity	20 to 80 %	
Supplied accessories	Analog camera input cable, Installation manual, Warranty booklet	

*6 Total of all the channels. Maximum frame rate for one channel is 30 fps (NTSC)/ 25 fps (PAL).

Distributed by

© 2008 Sony Corporation. All rights reserved.
 Reproduction in whole or in part without written permission is prohibited.
 Features and specifications are subject to change without notice.
 All non-metric weights and measurements are approximate.
 Projected images in this brochure are simulated.
 Sony is a registered trademark of Sony Corporation.
 Microsoft is a registered trademark of Microsoft Corporation.
 HDMI is a trademark or a registered trademark of HDMI Licensing LLC.
 All other trademarks are the property of their respective owners.